

# JDSK SERIES

## Submersible Cutter Sewage Pump



JDSK 2~7.5HP



JDSK 1/3~1 HP

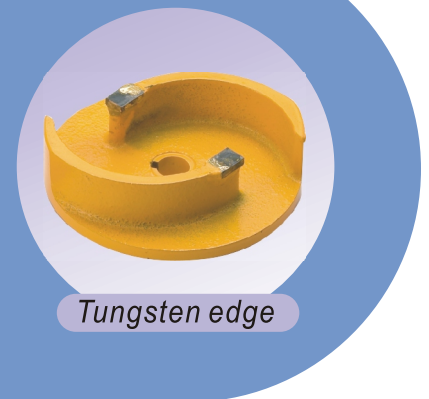

Tungsten edge

### Feature:

- Tipped with tungsten cutter to cut off foreign objects and prevent from clogging.

### Application:

- Hospital, school, building....etc.
- Wastewater treatment system ; Industrial wastewater and ground water drainage.



### Parts and Material List

NO	PART	MTRL
1	Cable	VCT
2	Cable hood	PVC
9	Handle	Nylon 6/SS41
15	Motor cover	Nylon 66/ FC 200
16	Seal housing	FC 200
17	Bracket	FC 200
18	Oil chamber	FC 200
20	Pump casing	FCD 450/ FC 200
21	Impeller	FCD 450
22	Strainer	FCD 450
25	Mech. Seal	CA/CE
26	Oil seal	NBR
41	Cutter edge	Tungsten
52	Bearing	(NTN)
53	Protector	(T.I./YAMADA)
54	Shaft	SUS 410
65	Motor housing	SUS 304

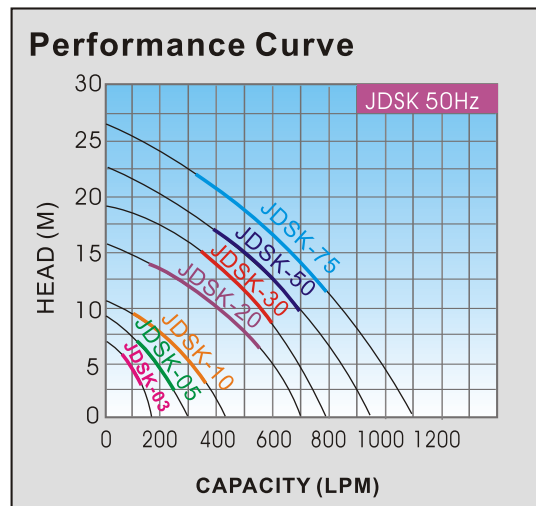

## Construction

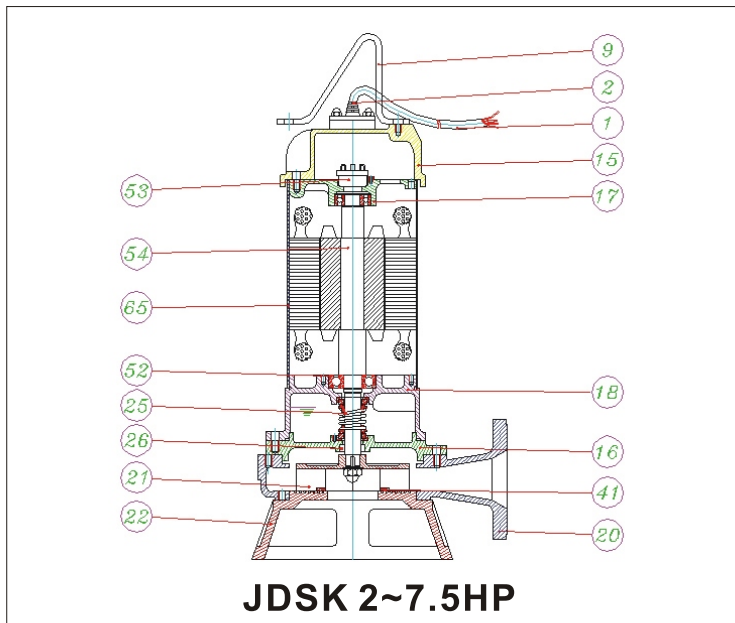

## Dimension

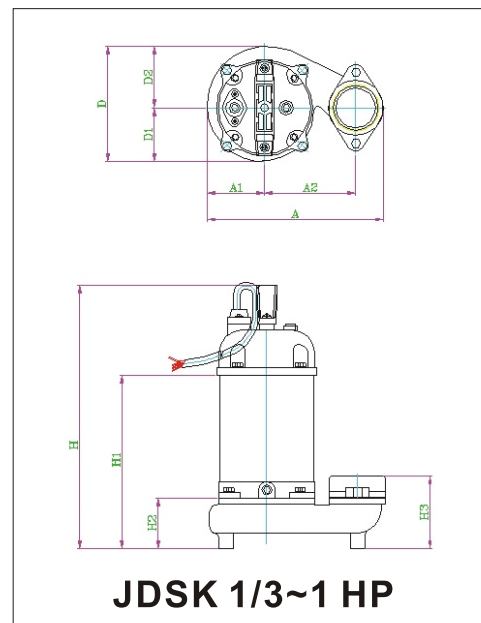
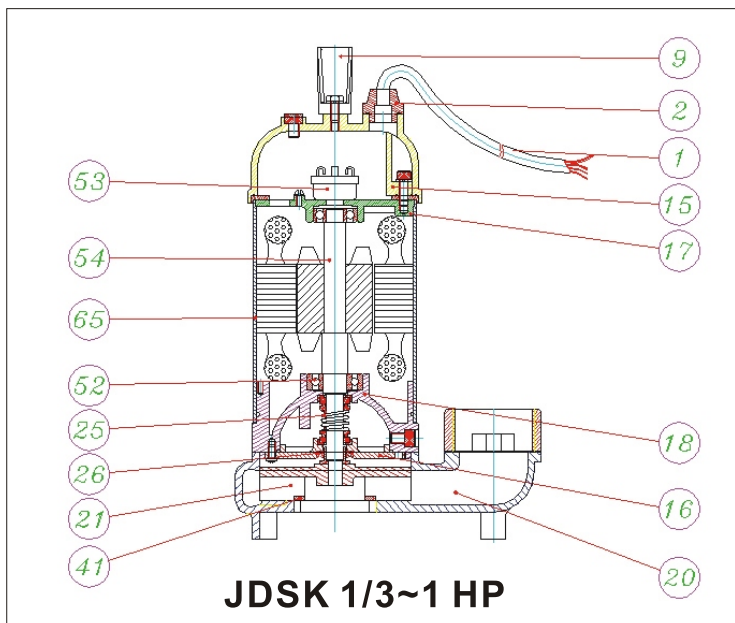
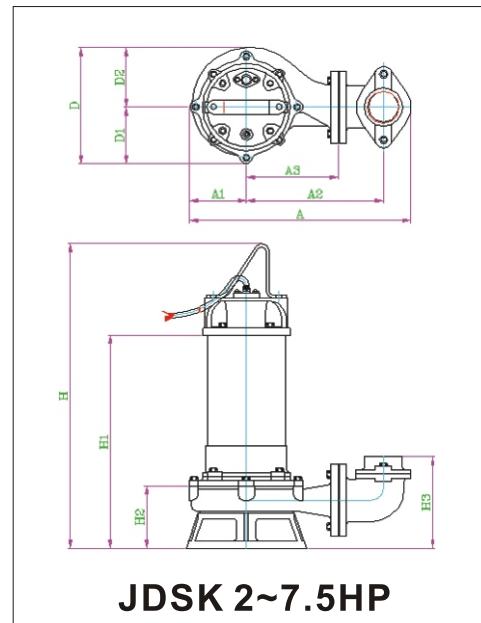

## Specifications

Type	Output HP	Discharge Inch	Phase $\phi$	Rated		Maximum		Dimension (mm)											Cable M
				Head M	Capacity LPM	Head M	Capacity LPM	A	A1	A2	A3	D	D1	D2	H	H1	H2	H3	
JDSK-03	1/3	2"	1.3	5	80	9	180	223	73	115	NA	146	68	78	307	220	64	92	5
JDSK-05	1/2	2"	1.3	6	150	9.5	300	223	73	115	NA	146	68	78	332	220	64	92	5
JDSK-10	1	2"	1.3	8	190	11	430	223	73	115	NA	146	68	78	362	250	64	92	5
JDSK-20	2	2"(3")	1.3	10	360	15.5	700	403	103	250	168	212	103	109	560	390	115	168	5
JDSK-30	3	2"(3")	3	11	440	18.5	800	403	103	250	168	212	103	109	580	410	115	168	5
JDSK-50	5	3"(4")	3	8	690	22.5	950	458(509)	110	256(294)	176	227	110	117	610	445	137	225	10
JDSK-75	7 1/2	3"(4")	3	12	750	26.5	1100	458(509)	110	256(294)	176	227	110	117	650	485	137	225	10

Note1: Automatic models are available in single-phase versions.

Note2: Q.D.C. (Quick Discharge Connection) is applied in all models.